

SENSOR S15

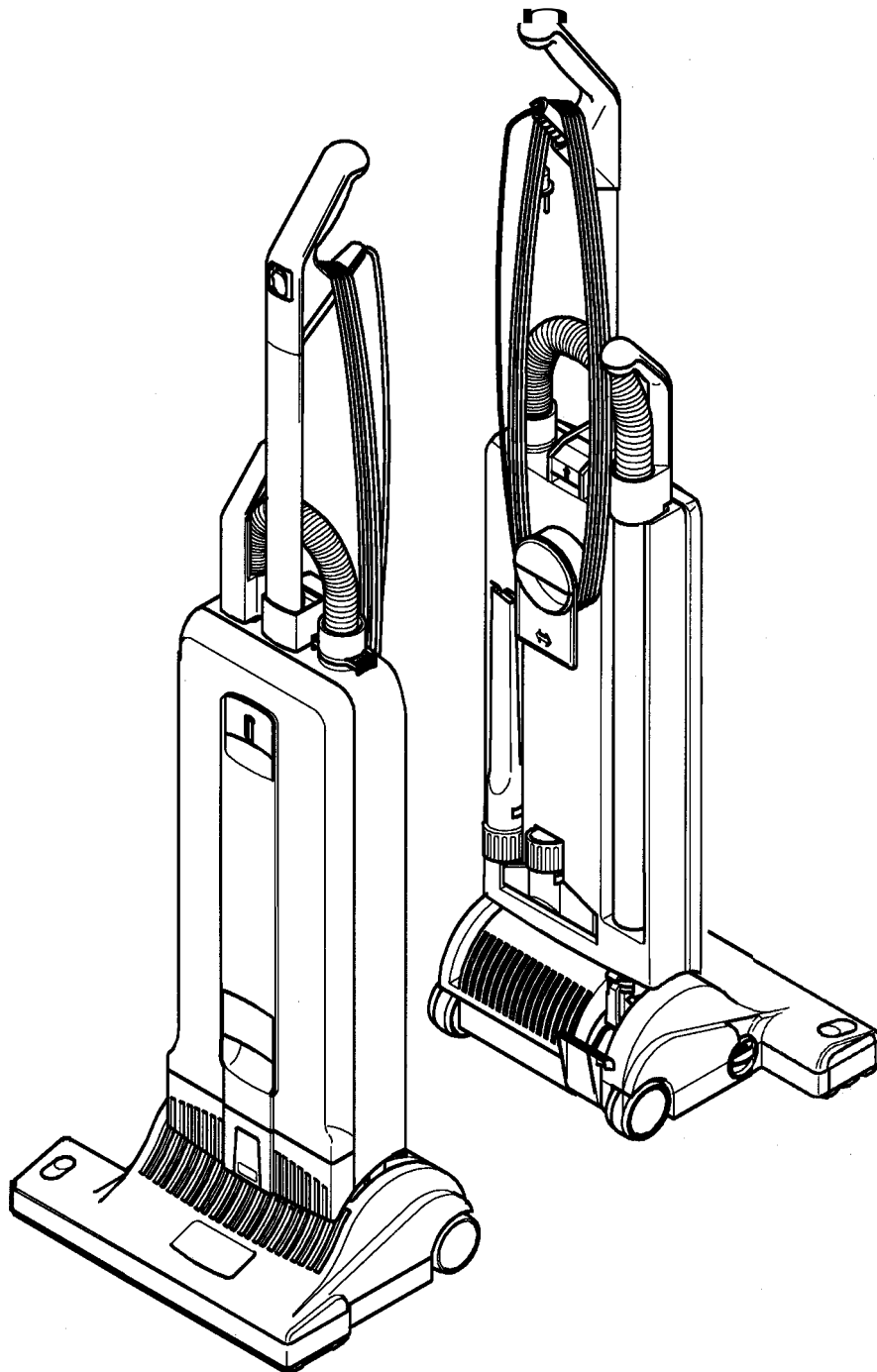

IMPORTANT SAFETY INSTRUCTIONS

When using an electrical appliance, basic precautions must always be followed, including the following.

READ ALL INSTRUCTIONS BEFORE USING THIS MACHINE

WARNING: To reduce the risk of fire, electric shock, or injury:

1. Do not leave appliance when plugged in. Unplug from outlet when not in use and before servicing.
2. Do not use outdoors or on wet surfaces.
3. Do not use near small children. Do not allow to be used as a toy. Close attention is necessary when used by or near children.
4. Use only as described in this manual. Use only manufacturer's recommended attachments.
5. Do not use with damaged cord or plug. If appliance is not working as it should has been dropped, damaged, left outdoors, or dropped into water, return it to a service center.
6. Do not pull or carry by cord, use cord as a handle, close a door on cord, or pull cord around sharp edges or corners. Do not run appliance over cord. Keep cord away from heated surfaces.
7. Do not unplug by pulling on cord. To unplug, grasp the plug, not the cord.
8. Do not handle plug or appliance with wet hands.
9. Do not put any object into openings. Do not use with any opening blocked; keep free of dust, lint, hair, and anything that may reduce air flow.
10. Keep hair, loose clothing, fingers, and all parts of body away from openings and moving parts., Do not place fingers or other body parts under vacuum unless unplugged.
11. Do not pick up anything that is burning or smoking, such as cigarettes, matches, or hot ashes.
12. Do not use without dust bag and/or filters in place.
13. Turn off all controls before unplugging.
14. Use extra care when cleaning on stairs.
15. Do not use to pick up flammable or combustible liquids such as gasoline or use in areas where they may be present.
16. Machines can cause a fire when operated near flammable vapors or materials. Do not operate this machine near flammable fluids, dust or vapors.
17. Maintenance and repairs must be done by qualified personnel.
18. Use only identical replacement parts. See instructions for Servicing of Appliances.
19. Do not use machine as a step.
20. If used on plush carpet or carpet with thick padding, do not leave machine in one place with machine turned on.
21. Do not use the handle in the dust bag housing cover to carry the machine.
22. Always turn off this appliance before connecting or disconnecting motorized nozzle.
23. Brush may unexpectedly restart. To reduce the risk of injury from moving parts. – Unplug before servicing.
24. The vacuum has a manual reset thermal protector. The protector is reset by switching off the vacuum. The thermal protector needs some time to cool down after switching off! Check the vacuum for air blockages or mechanical failures before switching on.
25. Store the vacuum in a dry place at room temperature. When the vacuum is not in use, you should wrap the cord on the cable hooks.
26. Any other servicing should be performed by an authorized service representative.

SAVE THESE INSTRUCTIONS

GROUNDING INSTRUCTIONS

This appliance must be grounded. If it should malfunction or breakdown, grounding provides a path of least resistance, for electric current to reduce the risk of electric shock. This appliance is equipped with a cord having an equipment-grounding conductor and grounding plug. The plug must be inserted into an appropriate outlet that is properly installed and grounded in accordance with all local codes and ordinances.

WARNING

Improper connection of the equipment-grounding conductor can result in a risk of electric shock. Check with a qualified electrician or service person if you are in doubt as to whether the outlet is properly grounded. Do not modify the plug provided with the appliance - if it will not fit the outlet, have a proper outlet installed by a qualified electrician.

This appliance is for use on a nominal 120-volt circuit, and has a grounded plug that looks like the plug illustrated in sketch A. A temporary adaptor that looks like the adaptor illustrated in sketches B and C may be used to connect this plug to a 2-pole receptacle as shown in sketch B if a properly grounded outlet is not available. The temporary adaptor should be used only until a properly grounded outlet (sketch A) can be installed by a qualified electrician. The green colored rigid ear, lug, or the like extending from the adaptor must be connected to a permanent ground such as a properly grounded outlet box cover. Whenever the adaptor is used, it must be held in place by a metal screw.

Note: In Canada, the use of a temporary adaptor is not permitted by the Canadian Electrical Code.

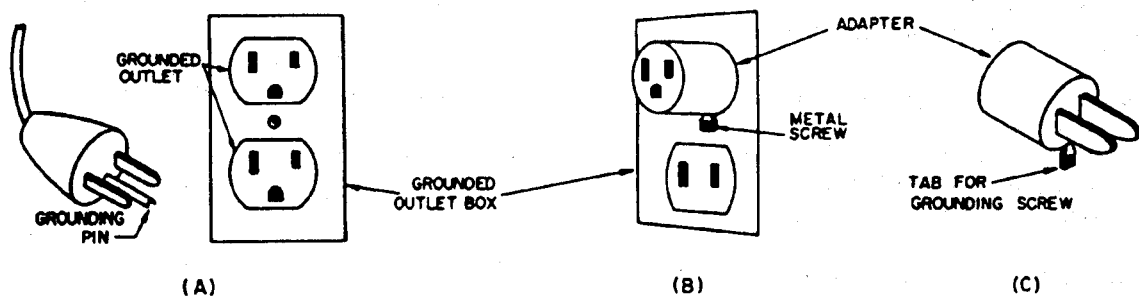

LIMITED WARRANTY

WINDSOR warrants to the original purchaser/user that this product is unconditionally guaranteed free from defects in workmanship and materials under normal use and service for a period of one year. The vacuum motor and belts are warranted for a period of two years.

WINDSOR will, at its option, repair or replace without charge, except for transportation costs, parts that fail under normal use and service when operated and maintained in accordance with the Instructions Manual. This warranty does not apply to normal wear or to items whose life is dependent on their use and care.

This warranty is in lieu of all other warranties, expressed or implied, and releases WINDSOR from all other obligations and liabilities. It is applicable only in the **U.S.A.** and Canada, and is extended only to the original user/purchaser of this product. WINDSOR is not responsible for costs for repairs performed by persons other than those specifically authorized by WINDSOR. This warranty does not apply to damage from transportation, alterations by unauthorized persons, misuse or abuse of the equipment, use of noncompatible chemicals, or damage or losses of income due to malfunctioning of the product. If a difficulty develops with this product, you should contact the dealer from whom it was purchased.

Important Safeguards

Accidents due to misuse can only be prevented by those using the machine. To guard against injury, basic safety precautions should be observed, including the following:

Read and follow all safety instructions.

WARNING: ELECTRIC SHOCK COULD OCCUR IF USED OUTDOORS OR ON WET SURFACES

This vacuum cleaner is designed to be safe when used to perform cleaning functions. Should damage occur to electrical or mechanical parts, cleaner should be repaired by WINDSOR or competent service station before using in order to avoid further damage to machine or physical injury to user.

A damaged power cord could cause electrical shock and/or fire. To minimize this possibility observe the following precautions:

Do not run cleaner over power cord.

Avoid closing doors on power cord, pulling it around sharp edges, or placing sharp-edged objects upon it.

Wind cord no tighter than is necessary to retain it on the cord hooks.

When disconnecting power cord from electrical outlet, grasp the plug. Pulling it out by the cord itself can damage cord insulation and internal connections to plug.

Your vacuum cleaner creates suction and contains a revolving brush. To avoid bodily injury from suction or moving parts, vacuum cleaner brush should not be placed against, or in close proximity of loose clothing, jewelry, hair or body surfaces while cleaner is connected to electrical outlet. Cleaner should not be used to vacuum clothing while it is being worn. Keep children away from machine when in operation or plugged in.

If used on plush carpet or carpet with thick padding, turn off unit when handle is in upright position. When using accessory tools, keep floor brush off carpet by keeping handle in locked position and lowering handle with one hand to raise brush off floor. Operate accessories with other hand.

Always plug your cleaner into a standard wall outlet. Use of extension cord or light socket with inadequate current-carrying capacity could result in electric shock or fire hazard.

Disconnect cleaner from electrical outlet before servicing, such as changing bags or belts. You could receive bodily injury from moving parts of machine should switch accidentally be turned on. Disconnect cleaner from electrical outlet before detaching powerhead.

Do not use your vacuum cleaner in areas where flammable and/or explosive vapor or dust is present to avoid possibility of fire or explosion. Some cleaning fluids can produce such vapors. Areas on which cleaning fluids have been used should be completely dry and thoroughly aired before being vacuumed.

To avoid fire hazard, do not pick up matches, fireplace ashes, or smoking material with cleaner.

Keep your work area well lighted to avoid picking up harmful materials (such as liquids, sharp objects, or burning substances) and avoid tripping accidents.

Use care when operating the cleaner on irregular surfaces such as stairs. A falling cleaner could cause bodily injury and/or mechanical damage. Proper storage of machine in an out-of-the-way area immediately after use will also prevent accidents caused by tripping over cleaner.

Store your vacuum indoors in a cool, dry area not exposed to the weather to avoid electrical shock and/or cleaner damage.

Exercise strict supervision to prevent injury when using vacuum cleaner near children or when child is allowed to operate vacuum cleaner. Do not allow children to play with vacuum cleaner and never leave cleaner plugged in and unattended.

SAVE THESE INSTRUCTIONS

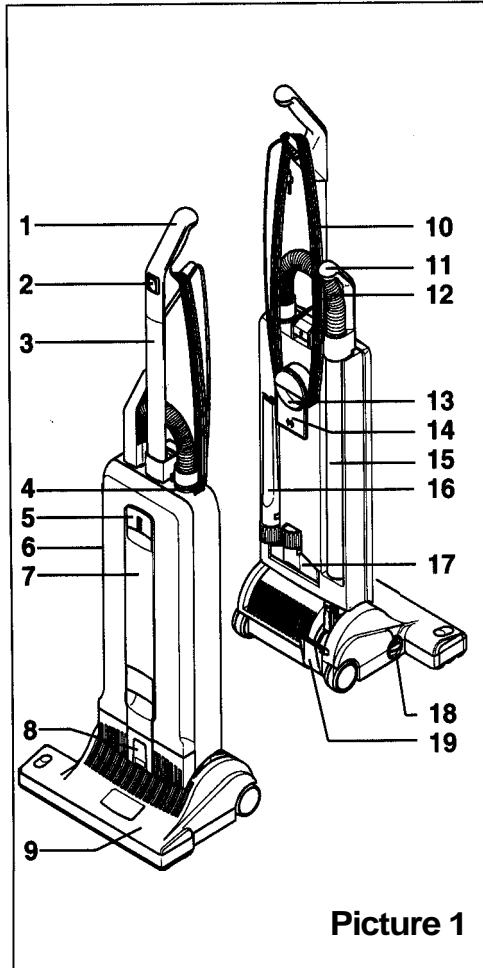

Picture 1

- 1 Handle grip
- 2 On/Off switch
- 3 Handle assembly
- 4 Retaining ring
- 5 Cover release flap
- 6 Dust bag housing
- 7 Front cover
- 8 Housing release button
- 9 Base with brush
- 10 Cable
- 11 Attachment tube handle
- 12 Hose
- 13 Carrying handle
- 14 Cable hook
- 15 Attachment tube
- 16 Crevice nozzle
- 17 Upholstery nozzle
- 18 Pile adjustment knob
- 19 Foot pedal

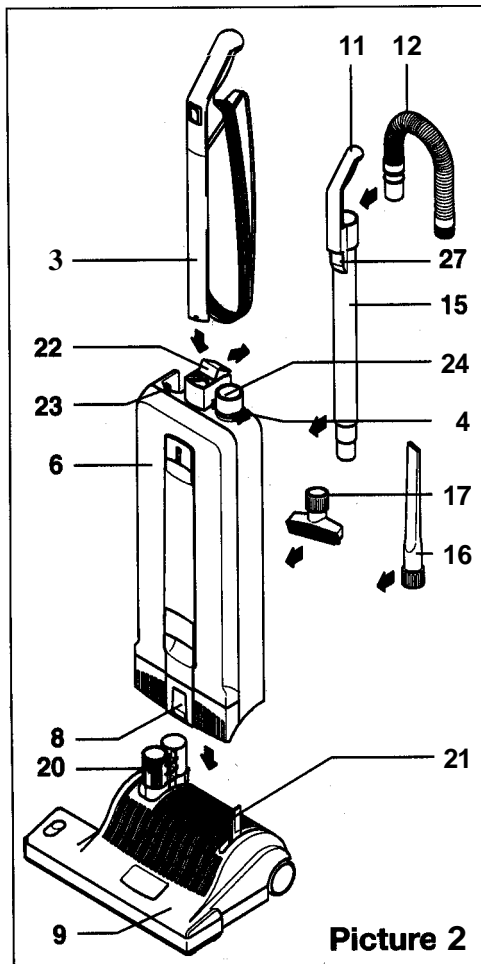

Picture 2

Preparation

Place the brush/suction head on a flat surface with the neck (20) and the support lever (21) upright. Hold the dust bag housing vertically and place over neck and support lever. Push firmly down so that the housing release (8) snaps closed.

Lift the catch (22) then slot the handle assembly into the top of the dust bag housing (6) and push firmly down.

When the handle has been pushed down as far as it will go press catch (22) down. If the handle is not pushed fully down the machine will not work.

Insert attachment tube (15) into the channel at the back of the machine. Locate the handle grip (11) on the holder (23).

Push the black end of the hose into the connecting tube (24), so that it clicks into place.

Insert crevice nozzle and upholstery nozzle into the recesses in the back of the machine.

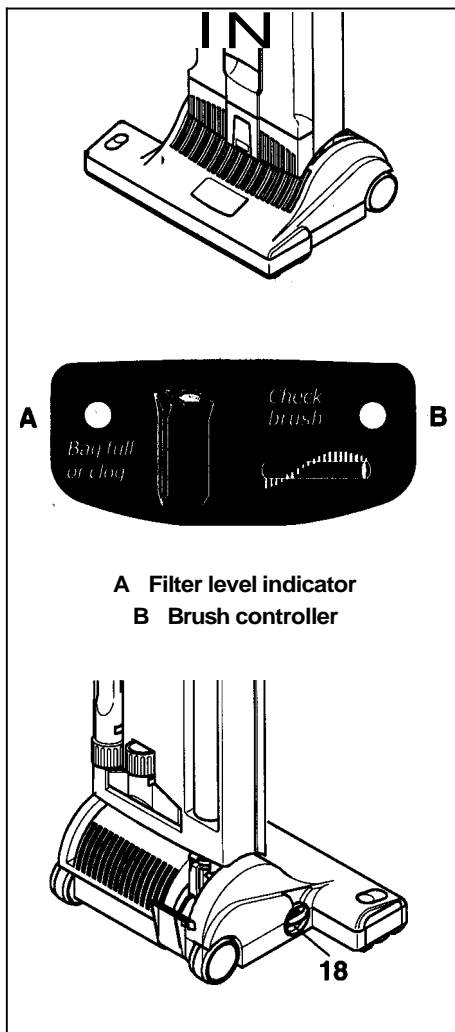

Filter level indicator

The red warning light (A) indicates a blockage or a full bag, so check:

- Is the dust bag full?
- Is there a blockage in the hose or power head?

If the red light is disregarded the machine will shut off and the light will flash.

Brush controller

The electronic brush controller continuously monitors the operation of the brush.

If the red light (B) stays off, the operation of the brush is correct.

If the red light (B) turns on in positions 1 - 4 of the Pile adjustment knob adjust the brush by turning the Pile adjustment knob to a lower position.

If the red light (B) burns continuously in the position 1, the brush must be changed for a new one.

If the machine turns off and the red light (B) flashes, the brush has become blocked and is not turning. Switch the machine off, unplug it from the mains and clear the blockage.

If there is no blockage, and machine turns off with brush light flashing, raise brush to a higher position.

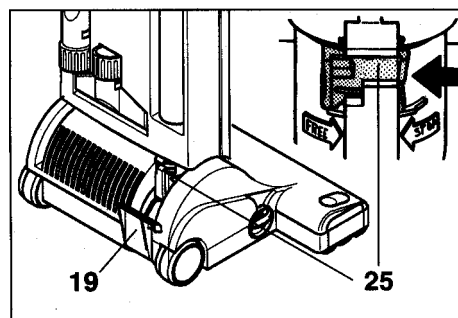

When the machine is switched on in the upright position the brush automatically rises from the carpet. To release the machine from the upright position, press down the foot pedal (19). The brush will automatically lower. The handle can be lowered to an intermediate stop position in order to lift up the brush head. To lower the handle to a horizontal position, the foot pedal must be pressed a second time. The stop position can be closed off by a slider on the swivel neck (25) so that the handle will go from vertical to horizontal in one movement.

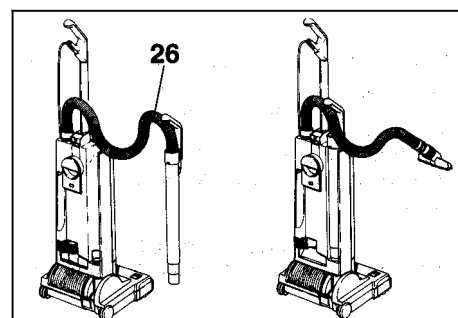

To vacuum in corners etc.:

take hold of the telescopic handle grip, lift, it away from the machine and stretch out the hose. After use insert the telescopic attachment tube into the back of the machine. Raise the handle of the machine and the hose will automatically retract. To use the hose without the tube as shown in the right hand picture, the hose will pull out of the tube while the tube is fitted to the machine. Alternatively, press the release catch (27) on picture 2.

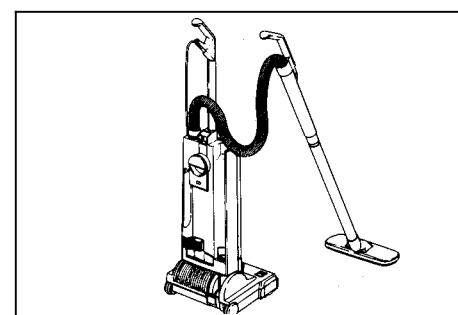

To vacuum under beds etc., the machine can be fitted with an additional straight tube and the floor nozzle. The machine will then perform as a cylinder vacuum.

Never run over the cable with the brush/suction head.
Always carry the machine over steps and sills.

Maintenance

CAUTION - Always unplug machine at mains outlet before dismantling any part of machine.

If red light (A) shows, change paper filter bag. To do this first pull cover release (5) picture 1 forward and lift the cover from the dust bag housing. Slide the dust bag sealing plate (28) from the holder (29). Slide the sealing plate (28) of a new bag into the holder and push firmly in. Insert cover into dust bag housing push is forward then lock it in place by pushing down the cover release (5).

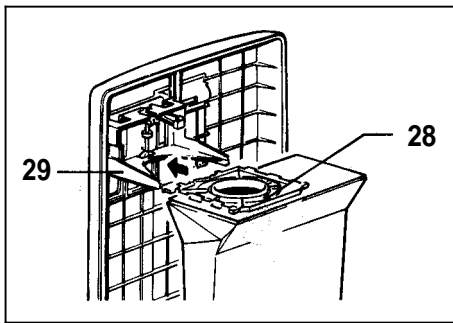

The micro hygiene filter (30) needs to be changed when it becomes clogged with dust or after approximately 20 paper bags have been used. To change the hygiene filter first remove the cover then slide the filter out at the bottom. To replace lift the lever and slide the new filter in.

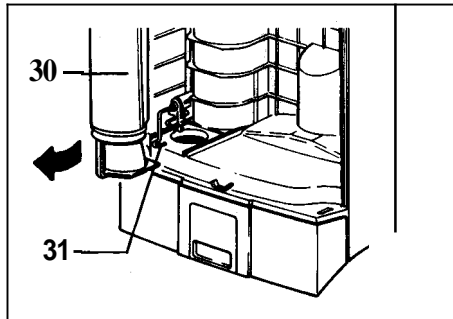

After 20 paper bags have been used also change the exhaust filter (32). To remove the exhaust filter push the catch (33) forward and remove the filter cover (34) and filter. Insert the new filter and replace the filter cover.

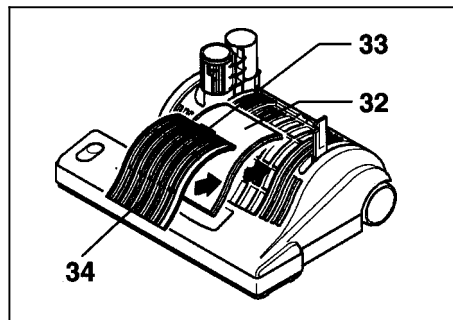

To change the brush roller (35) push the button (36), remove the slide plate (37), turn the brush clockwise a quarter of a turn and pull the brush roller out. Slide the new brush roller into the brush housing and turn it until it locates into position. Push the button (36) and press the slide plate (37) back into place.

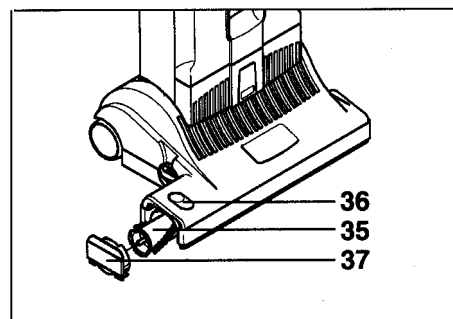

Underneath the machine is an inspection door to check for blockages (38). Blockages in the neck (20 - picture 2) can be checked by first lifting off the dust bag housing by pressing the catch (8). Then release the foot pedal, lower the neck and check into the tube next to the pedal.

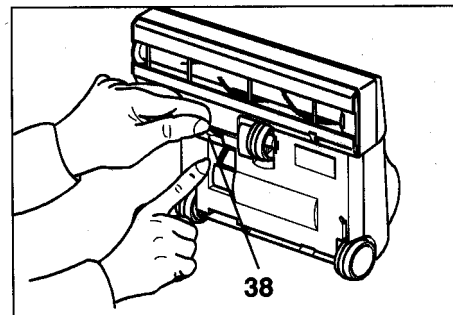

Blockages in the hose can be cleared by taking the hose off the machine and replacing it the wrong way round in the connecting tube (24) holding it upright with one hand blocking the top and switching on the machine. (If necessary quickly lift your hand on and off the end of the hose).

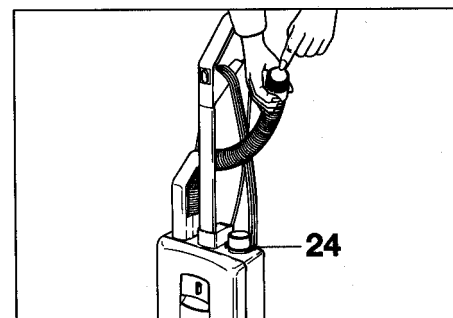

The guarantee is invalidated if take out parts not approved by WINDSOR, eg. bags, filters, brush roller, etc., are fitted!

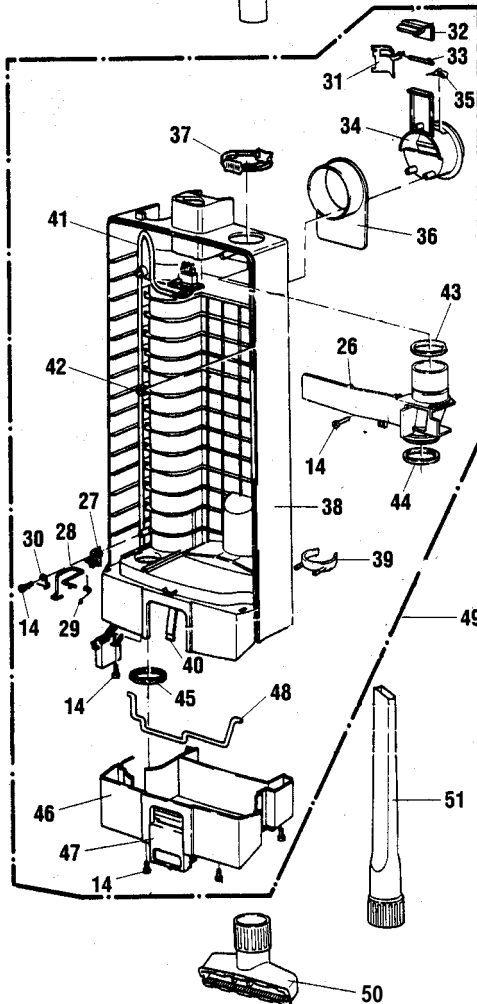
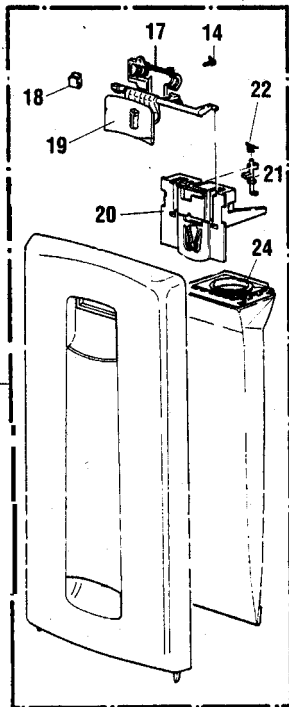
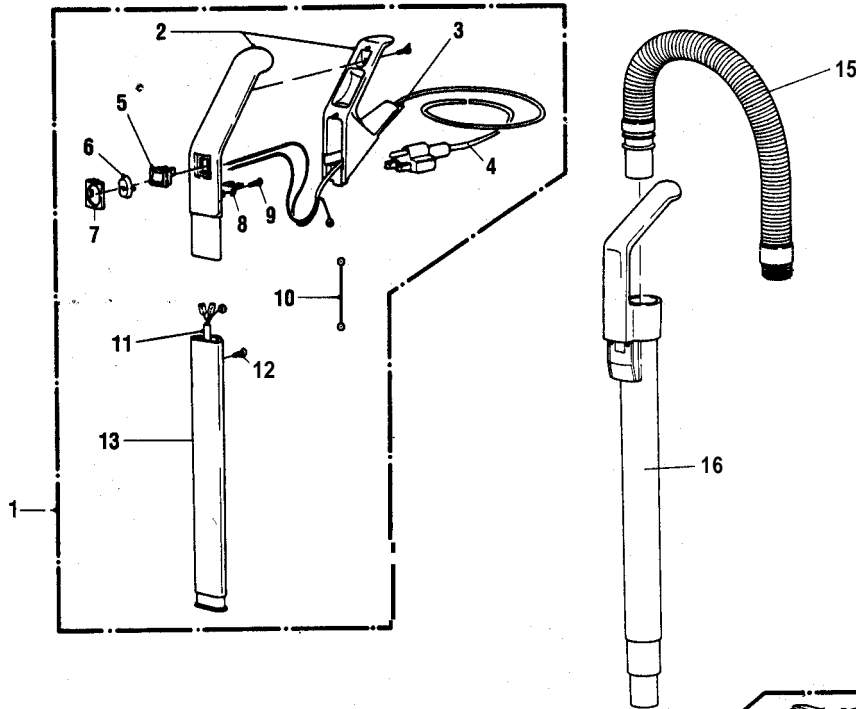

Pos.	Product-No.	Description
1	5625 UL	Handle with cable, cpl.
2	5296 EW	Handle grip (incl. Pos. 7 + 10)
3	5359 hg	Grommet
4	23011	Power supply cord
5	0532 EW	Switch, cpl.
6	5160 bl	Switch cap, blue
7	5161 hg	Switch cap holder
8	5162	Cable clamp
9	0103	Screw C 3,9 x 16 DIN 7981
10	0846	Antistatic-wire, cpl.
11	5256 ER	Handle cable
12	0129	Screw, M4x 12
13	5187	Handle tube
14	0102	Screw F 39 x 13 DIN 7981
15	5040 hg	Hose, cpl.
16	5045 hg	Extension tube
17	5803 hg	Cover
18	5319	Bag holder spring
19	5706 bl	Cover release, blue
20	5324	Bag holder cpl. (incl. Pos. 20 + 21)
21	5360	Safety catch
22	5091	Safety catch spring
23	5800 WI	Front cover cpl.
24	5300	Paper bag
25	5301 ER	Micro Hygiene Filter
26	5380 HG	Internal cover, compl. (incl. Pos. 43 + 44)
27	5164	Cable clamp
28	5208	Filter safety catch
29	5210	Return spring
30	1073	Clamp
31	5099	Handle lock plate
32	5098 hg	Lock catch
33	0187	Lock pin 4 x 33,5
34	5145 hg	Carrying handle
35	5146	Stop spring
36	5144 hg	Cable hook
37	5424 dg	Retaining ring
38	5281 hg	Dust bag housing
39	1823 hg	Attachment clip
40	5084	Spring for locking rod
41	5255 ER	Internal cable
42	5266	Cable clamp
43	5043	Seal
44	5289	Seal
45	5163	Seal
46	5085 hg	Dust bag hous. bumper base
47	5082 bl	Dust bag housing locking
48	5083	Locking rod
49	5215 UL	Dust bag housing
50	1491 JE	Upholstery nozzle
51	1092 JE	Crevice nozzle

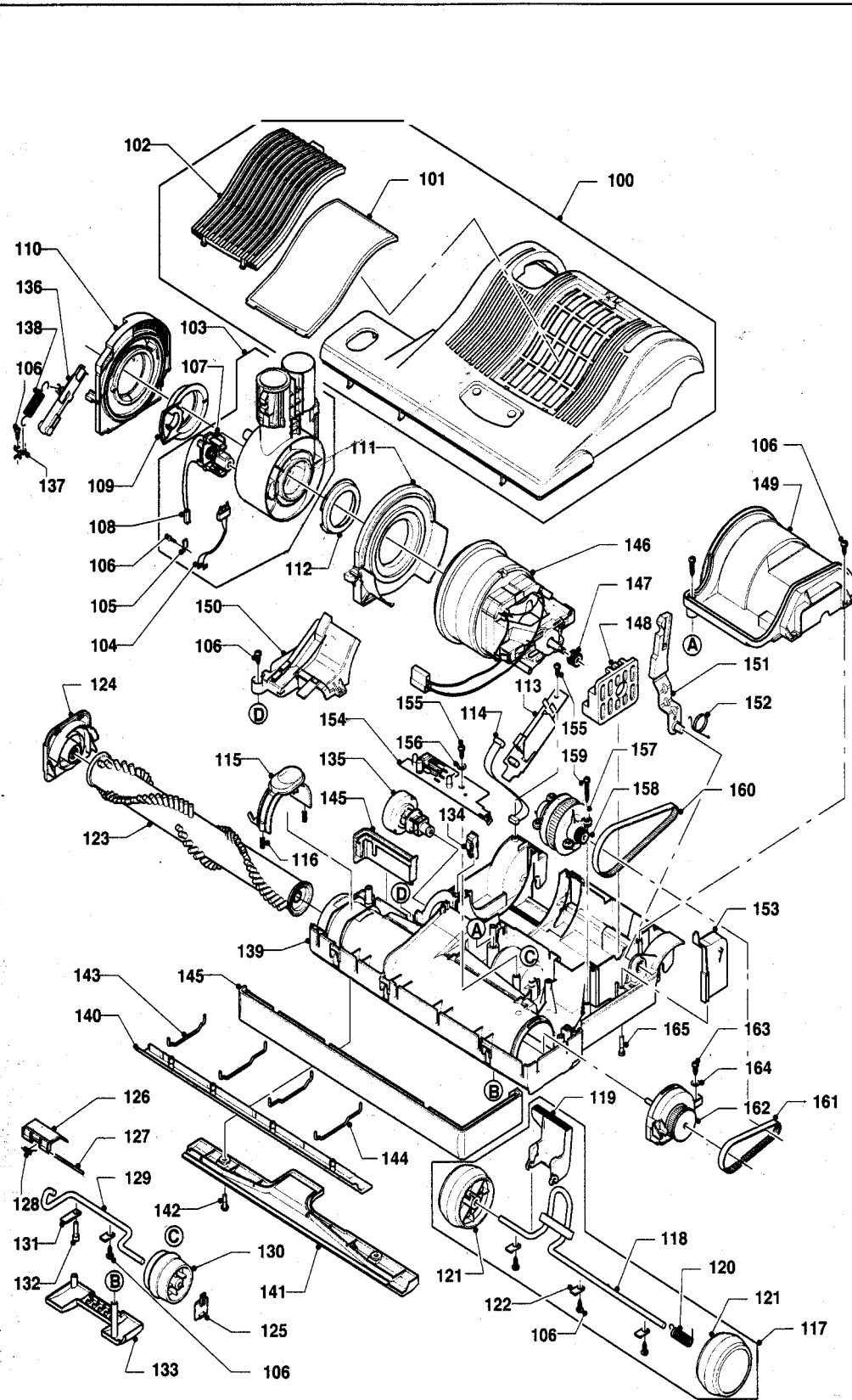

Pos.	Product-No.	Description
100	2832 WI	Power head cover S 15, cpl
101	2846	Exhaust filter
102	2820 BL	Exhaust filter cover
103	2827 UL	Swivel neck assembly
104	2886	Male contact holder
105	2494	Cable clamp
106	0102	Screw F 3,9 x 13 DIN 7981
107	2835	Bypass valve
108	0869	Internal cable
109	2825	Swivel neck bearing r.h
110	2824	Swivel neck support r.h
111	5479	Swivel neck support l.h
112	5717	Swivel neck bearing l.h
113	2890 ER	PCB Power supply
114	0864	Internal cable
115	5713 bl	Brush roller release
116	5103	Spring
117	5051 hg	Axle assembly
118	5053	Axle
119	5059 dg	Foot pedal
120	2010	Axle spring
121	5055 hg	Wheel, cpl.
122	2014	Axle clamp
123	5814	Brush roller
124	5287 bl	Bearing block righthand
125	2869 hg	Rubbing plate
126	2868 or	Access door (incl. Pos. 127 + 128)
127	5303	Access door axle
128	5304	Access door spring
129	2861	Pile adjustment axle
130	5174 hg	Pile adjustment wheel
131	2849	Axle clamp
132	01010	Screw AM4 x 16, DIN 7985
133	2860 hg	Cover
134	2833	Thrust member
135	2862 hg	Pile adjustment knob
136	2834	Thrust member
137	2856	Clamp
138	2867	Spring
139	2822 HG	Chassis G2, cpl
140	2828 hg	Front bottom plate G2, cpl.
141	2830 hg	Rear bottom plate G2, cpl. (incl. Pos. 142)
142	0197	Screw M4 x 12 Z 1
143	5401	Wire tie
144	5402	Wire tie
145	2842 hg	Bumper, set
146	5469	Motor 1000W / 120V
147	05117 S	Carbon brush set
148	5462	Motor pulley 2MR
149	5100	Rubber mounting
150	2826 BL	Motor cover
151	2839 sw	Cover for air channel
152	5129	Support lever
153	5107-1	Support spring
154	5112 sw	Motor pulley cover
155	2881 ER	Computer controller
156	0107	Screw C 2,9 x 13
157	0143	Washer 3,2 DIN 125
158	5465	Sensor (with red ring)
159	5117/1	Motor pulley
160	0104	Screw C 3,9 x 25 DIN 7981
161	5463	Belt 2MR-310-6
162	5110	Belt 219 3M HTDII-6
163	5766 hg	Bearing block l.h cpl.
164	0103	Screw C 3,9 x 16 DIN 7981
165	0140	Washer 4,3
166	0176 TL	Screw AM4 x 30 DIN 7985 TL

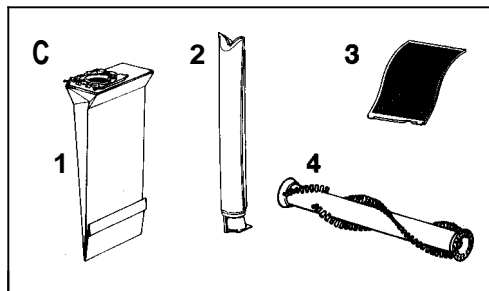
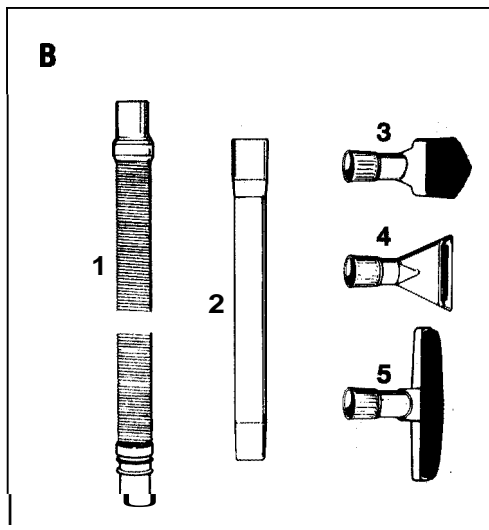
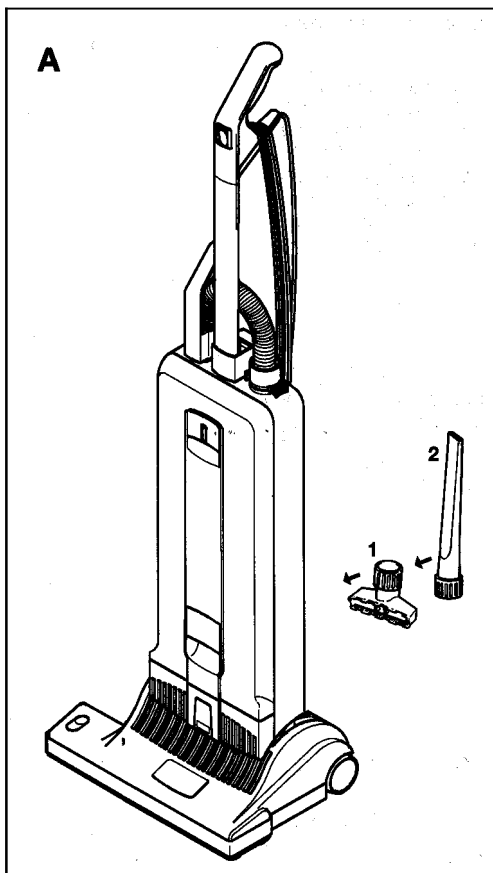

- A Attachments**
 1 Upholstery Nozzle
 2 Crevice Nozzle
- B Optional Attachments**
 1 Extension Hose
 2 Straight Tube
 3 Dusting Brush
 4 Upholstery Nozzle, special
 5 Wall- and Floor Brush
- C Service Parts**
 1 Paper Bag
 2 Micro-Hygiene-Filter
 3 Exhaust Filter
 4 Brush Roller

! **WARNING!** Electric shock could occur if used outdoors or on wet surfaces!

Technical Details

Vacuum motor.	1200 Watt
Water lift	2300 mm (50")
Air flow	50 <i>US</i> (105 CFM)
Dust bag capacity.	5,3 liters
Working width	378 mm (15")
Brush drive	tooth belt
Brush speed	2700 rpm
Floor adjustment	automatically sensor advised
Cable	12,2 m (40 ft)
Weight.	7,5 kg (16,4 lbs)
Radio supression.	EN 55014 Verf. 242/9

Wiring diagram

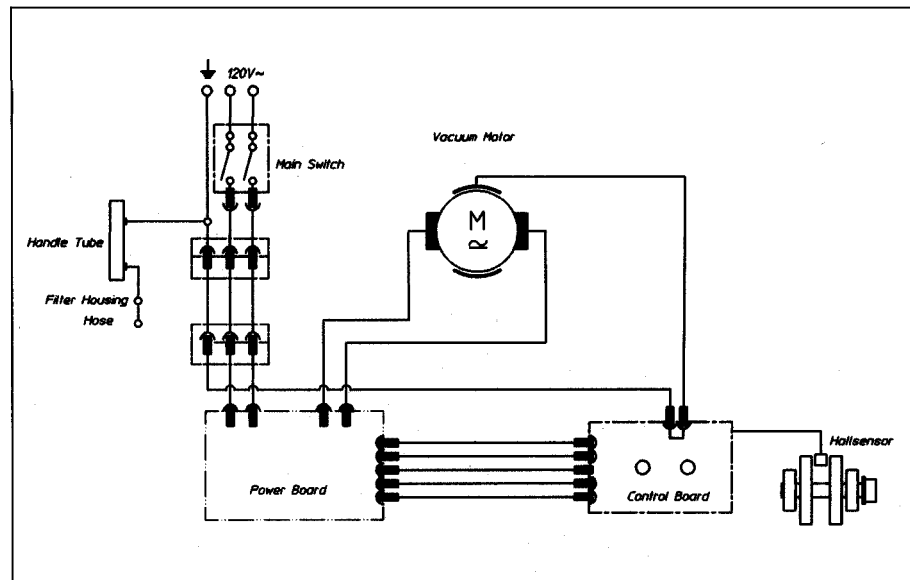

WINDSOR® INDUSTRIES, INC.

1351 West Stanford Ave.
 Englewood, Colorado 801.10 USA
 800-444-7654
 303-762-1800
 FAX: 303-762-0817